

Assembly Instructions

S:FLEX Carport



Sustainable energy securely anchored.

Introduction	
Intended use	3
About this document	3
Warnings	4
General information – standards and guidelines	4
Description of the system	6
Assembly of S:FLEX Carport	
System components	7
Important assembly instructions	10
Assembly Carport	12
Assembling the gutter	25
Disassembly and disposal	
Disassembly	27
Disposal	27
Terms of use and warranty	
User agreement	28
Warranty / disclaimer	28

Read these installation guidelines carefully before installing the S:FLEX mounting system and retain them for future reference!

These installation guidelines are only complete with the project-specific implementation plans (project report)!

Intended use

The S:FLEX Carport is a robust carport for the installation of PV modules on the roof. The scope of delivery consists of the basic framework in the form of steel profiles, roof covering and all necessary small parts for mounting the modules on the trapezoidal sheet. In addition, a roof edging and drainage is included.

About this document

These instructions describe the assembly of the S:FLEX carport. The attachment of the PV modules to the trapezoidal sheet metal is described in separate assembly instructions. In addition, these instructions contain systemspecific information for planning, safety instructions and a list of the components to be installed.

It is essential that you read these mounting instructions and all other applicable documents before starting mounting, maintenance and dismounting work. You will be given all information for safe and complete assembly, maintenance and disassembly. Should any questions arise, please contact S:FLEX GmbH.

User group

All assembly instructions of S:FLEX GmbH are intended for the following persons (user group):

- Qualified personnel
- Instructed personnel

Qualified personnel

Skilled personnel are those who, on the basis of their professional training, are able to carry out assembly, maintenance and disassembly work in a professional manner.

Instructed personnel

An instructed person is one who has been appropriately instructed and trained in the tasks assigned to him/her and the possible hazards of improper behavior. An instructed person must have been instructed about the necessary protective equipment, protective measures, relevant regulations, accident prevention regulations as well as operating conditions and must have proven his competence. The work performed must be approved by qualified personnel.

1.3 Warnings

The warning texts provided in these installation guidelines relay safety-related information. They are:



Unless observed, there is a major risk of injury as well as a risk of death.



Failure to observe this may lead to property damage.

1.4 General information – standards and guidelines

Each photovoltaic system must be installed in compliance with the specifications of these installation instructions and the project report.

These installation instructions are based on the state of the art and many years of experience in how our systems can be installed on site. It must be ensured that only up-to-date and complete installation instructions are used for installation and that a printout of the installation instructions is kept in the immediate vicinity of the system. We reserve the right to make technical changes.

The project report is part of the installation instructions and is prepared on a project-specific basis. All information in the project report must be adhered to. In the project report, the static calculations are carried out on a site-specific basis. The design and planning of the S:FLEX mounting systems must be carried out with the S:FLEX software.

Since individual project-related special features must be taken into account for each roof, expert clarification must always be provided prior to installation. Before installation, the PV system designer must ensure that the existing roof covering and roof substructure are designed for the additional loads that will occur. The installer must check the condition of the roof substructure, the quality of the roof covering and the maximum load-bearing capacity of the roof structure.

For this purpose, contact a specialist tradesman or structural engineer directly on site.

When installing the PV systems, always ensure that the module manufacturer's installation instructions are followed. In particular, it must be checked whether the module manufacturer's specifications regarding the module clamping specifications (number of clamping points, clamping surface and clamping area on the module) are adhered to. If this is not the case, the customer must obtain the module manufacturer's declaration of consent before installation or the frame must be adapted to the module manufacturer's specifications.

The requirements for lightning and overvoltage protection of mounting systems for PV systems must be established in accordance with DIN and VDE regulations. The specifications of the responsible power supply company must be complied with.

Care must be taken to ensure that the PV system to be installed does not impair the effect of the existing lightning protection system. It must also be ensured that the PV system is designed in such a way that it can be included in the protected area of the building lightning protection system. Separation distances between the PV system and the lightning protection system must be taken from the relevant regulations and complied with.

The applicable fire protection regulations must be observed during installation. Fire protection walls must not be built over, fire protection sections must be observed and corresponding spacing regulations must be complied with.

If changes are made to the roof covering, the manufacturer's regulations must be observed. During and after installation, the frame parts must not be walked on or used as climbing aids. There is a risk of falling and the roof covering underneath could be damaged.

It must be ensured by the creator of the photovoltaic system prior to installation that the installation is carried out strictly in accordance with national and site-specific building regulations, occupational safety and accident prevention regulations, standards and environmental protection regulations.

Every person who installs S:FLEX PV mounting systems is obliged to independently inform themselves about all rules and regulations for professionally correct planning and installation and also to comply with them during installation. This also includes obtaining the current status of rules and regulations.

The installation of the PV system may only be carried out by appropriately trained specialists.



All system components must be checked for damage before installation. Damaged components must not be used!



Installation of the S:FLEX substructure and the PV system may only be carried out by trained specialists. System components must not be used as step ladders. The modules must not be stepped on. When working on roofs, there is a risk of falling off and falling through roofs. A fall can result in injury or death. Ensure that appropriate climbing aids and fall-protection equipment (e.g. scaffolding) are provided as well as protection from falling parts.



Before installation, check the building statics and the structure/condition of the roof substructure. The specifications in the installation instructions and the project report must be observed during installation. Failure to observe the specifications in the installation instructions and the project report may result in damage to the PV system and the building.

Description of the system

System features of Carport

Included in delivery:	Carport: Trapezoidal sheet metal (Steel 0.75 mm), roof edging, drainage, supports. Solar fastening: S:FLEX trapezoidal sheet metal rail or high beading rail, module holder, screws, variable cable routing
Extendibility:	Modularly extendible to up to 12 freely combinable single/double segments for max. 24 parking spaces by means of extension sets.
Foundation:	Anchored to the floor/concrete (foundation to be provided by customer)
Height:	Clearance height: 2.09 m, max height: 2.95 m
Roof pitch:	6°
Module alignment:	horizontal, high
Module size:	all common sizes
Roof area / module field size:	Singles: 22 m ² /10 Module ¹ , ca. 3,8 kW Doubles: 35 m ² /15 Module ¹ , ca. 5,5 kW
Material:	Carport: galvanised steel, finished with a powder coating. Solar mounting: Aluminium
Small parts:	Stainless steel A2-70 A
Optional available:	Plate (without holes) for mounting inverter and/or charging pole
Colour:	RAL 7016 (anthracite grey)
Warranty	10 years on the durability of the materials

¹ PV modules à 1,06m x 1,8m/375 Wp

Snowload/Windload

S:FLEX Carport Load Overview	max. wind load (q _p -Value) [kN/m ²]	max. snow load incl. ndT (s _i -Value) [kN/m ²]
S:FLEX Carport Single	0,54	3,8
S:FLEX Carport Single	1,01*	0,88
S:FLEX Carport Double	0,66	0,68
S:FLEX Carport Double Extension	0,66	0,68

*when using 4 self-drilling screws per running metre of trapezoidal sheet metal (per purlin).

System components

Support



Rafters



Connecting sheet metal



Bracket



Gusset Plate



Z Purlins



Mounting Plate



Sheet Metal (cover)



Winkel Bracket (cover)



Tuning Plate



Gutter Holder



Gutter Outlet



Gutter



Elbow



Metal Pipe Bracket for pegged screw



Trapezoidal sheet

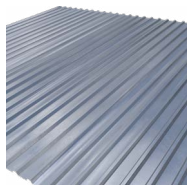

Drilling screw 5.5x0.8x19



Bolt anchor



Unpacking and assembly only with several people. Sheets can bend.

Number of components per basic package S:FLEX Carport

Label	Quantity Carport Single	Quantity Carport Double	Quantity Carport Extension
Support welded 120x120x3 l=2030 mm	2	2	1
Support welded 120x120x3 l=2470mm	2	2	1
Rafters DIN EN 10219-2 120x120x3 l=5600 mm	2	2	1
Connecting sheet metal	8	8	4
Bracket 74x210x12	12	12	6
Gusset Plate	4	4	2
Z Purlins 220; l=5900 mm	6	6	6
Mounting Plate 65°	0	4	4
Threaded Rods DIN 975 Galvanised grade 8.8 l=1150 mm	0	3	3
Threaded Rods DIN 975 Galvanised grade 8.8 l=1050 mm	0	1	1
Threaded Rods DIN 975 Galvanised grade 8.8 l=1250 mm	0	1	1
Threaded Rods DIN 975 Galvanised grade 8.8 l=2700 mm	0	2	2
Sheet Metal (cover) 258x3000 mm	3	3	1
Sheet Metal (cover) 260x1000mm	1	0	0
Sheet Metal (cover) 260x3000mm	2	3	1
Bracket (cover) 216x138x2000 mm	2	3	3
Tuning Plate 250x250x5	4	4	4
Trapezoidal sheet metal TR35_0,75mm S280GD with anti-condensation fleece 5,85x1,09m	4	7	7
Gutter Holder	7	9	9
Gutter Outlet 125/90	1	1	1
Gutter l=3000 mm	0	2	2
Gutter l=4000 mm	1	0	0
Elbow 60°	3	3	3
Universal Seal Endcap	2	2	0
Clamp Gutter Joiner	0	1	2
Metal Pipe Bracket for pegged screw	2	2	2
Pipe Ø 90x1,5 - 3000 mm	1	1	1
Bolt Anchor galvanised M20_160_30	16	16	8
Square Pipe Plug Louvre Plug 120x120 Anthracite	4	4	2
Cover plug 30x25 Drill hole Ø 25mm Anthracite	30	20	16
Cover plug 35x30 Drill hole Ø 30mm Anthracite	10	10	6
Hexagon screws M12x30	0	6	30
Hexagon screws M12x35	50	50	30
Socket head screw EN ISO 4762 M12 x 35 8.8 Galvanised	30	30	20
Hexagon socket head cap screws ISO4014 M16x150 8.8 Galvanised	10	10	6

Label	Quantity Carport Single	Quantity Carport Double	Quantity Carport Extension
Hexagon socket head cap screws ISO4014 M16x160 8.8 Galvanised	20	20	10
Hexagon nut M12	80	110	90
Hexagon nut ISO 4032 - M16 Galvanised 8.8	30	30	16
Washers M16 ISO 7089 Galvanised	60	60	24
Washer M12	150	200	160
Drill screws 5.5x0.8x19 hexagon head with sealing washer, galvanised DIN 7504-K	150	200	150
Drill screws 5.5x0.8x22 hexagon head without sealing washer, galvanised RAL 7016, DIN 7504-K	15	20	20
Screw Caps M12 Hexagon Grey	110	130	10
Screw Caps M16 Hexagon Anthracite	60	60	100
Screw Caps M20 Hexagon Anthracite	20	20	30
Plug-in socket Ø90 RAL7016	1	1	1

Important assembly instructions

Conditions of use

- No shading
- available space
- suitable surface



Too high a load can damage the roof!

For your own protection and to protect the trapezoidal sheet metal, use a wooden beam or similar as a stepping surface during assembly and installation.



Danger to life from falling parts!

Parts falling from the roof can cause serious injuries or death!

Before any assembly and installation, make sure that the material used meets the static requirements on site.

Assembly preparation

S:Flex GmbH recommends that you inform yourself about the conditions on site before ordering the carport. In particular, familiarise yourself with:

- Obtaining a building permit or building permit, if required.
- Preparation of the foundations
- We recommend at least 4 people for the construction.

Assembly aids and required tools

You will need the following tools to assemble the frame system:

- Hammer drill with concrete drill bit 20 mm
- hammer
- Drill/electric screwdriver
- Attachment for cordless screwdriver I
- Screwdriver spanner: SW 19, 24, 30
- Hexagon socket spanner SW 10
- Striking cord
- Spirit level or laser levelling device
- Folding rule/tape measure
- Torque wrench
- jack
- Screw clamp
- Saw (for downpipe)

Tightening moments:

- M12 - 86 Nm
- M16 - 215 Nm
- Bolt anchor M20 - 200 Nm

To the assembly descriptions

In the following chapters, all steps for planning and assembling the S:FLEX carport are listed in the correct order. Chapters 2.3 and 2.4 describe the assembly steps for carport construction, the chapters on module design are provided separately.

The assembly description is carried out using the Carport Double as examples.

Follow the assembly steps listed and be sure to observe the safety instructions.

Assembly Carport

Carport Single

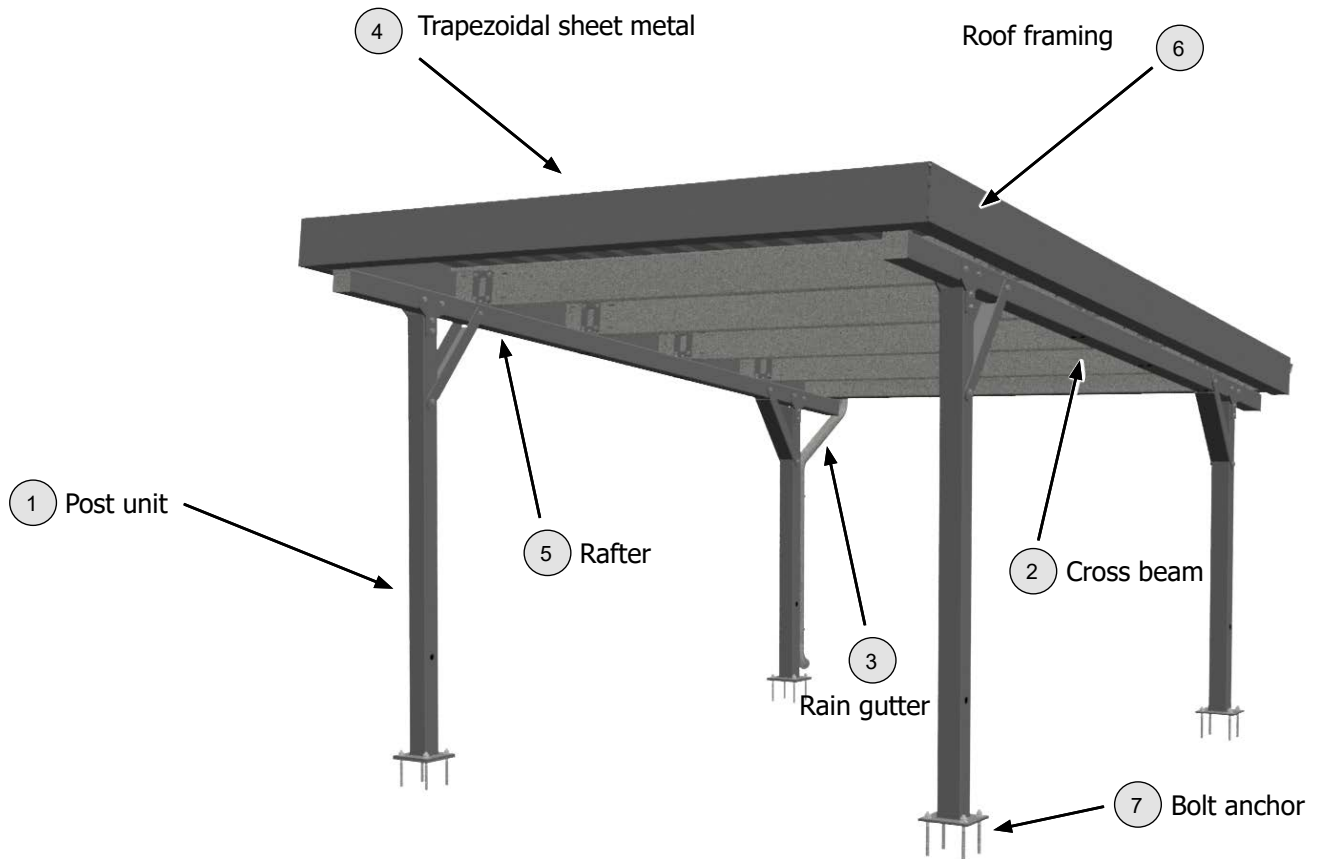

Carport Double

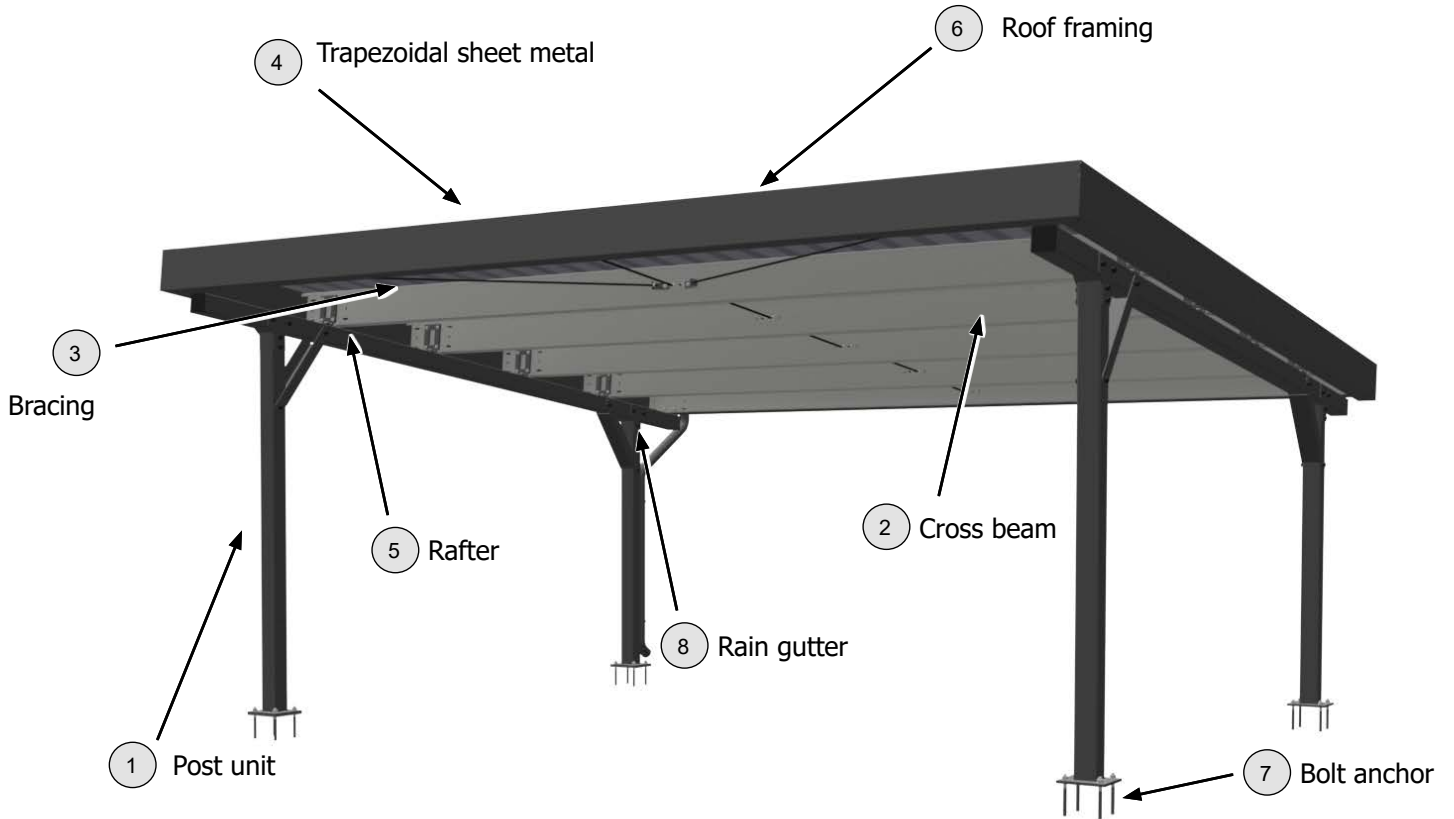

Carport Extension

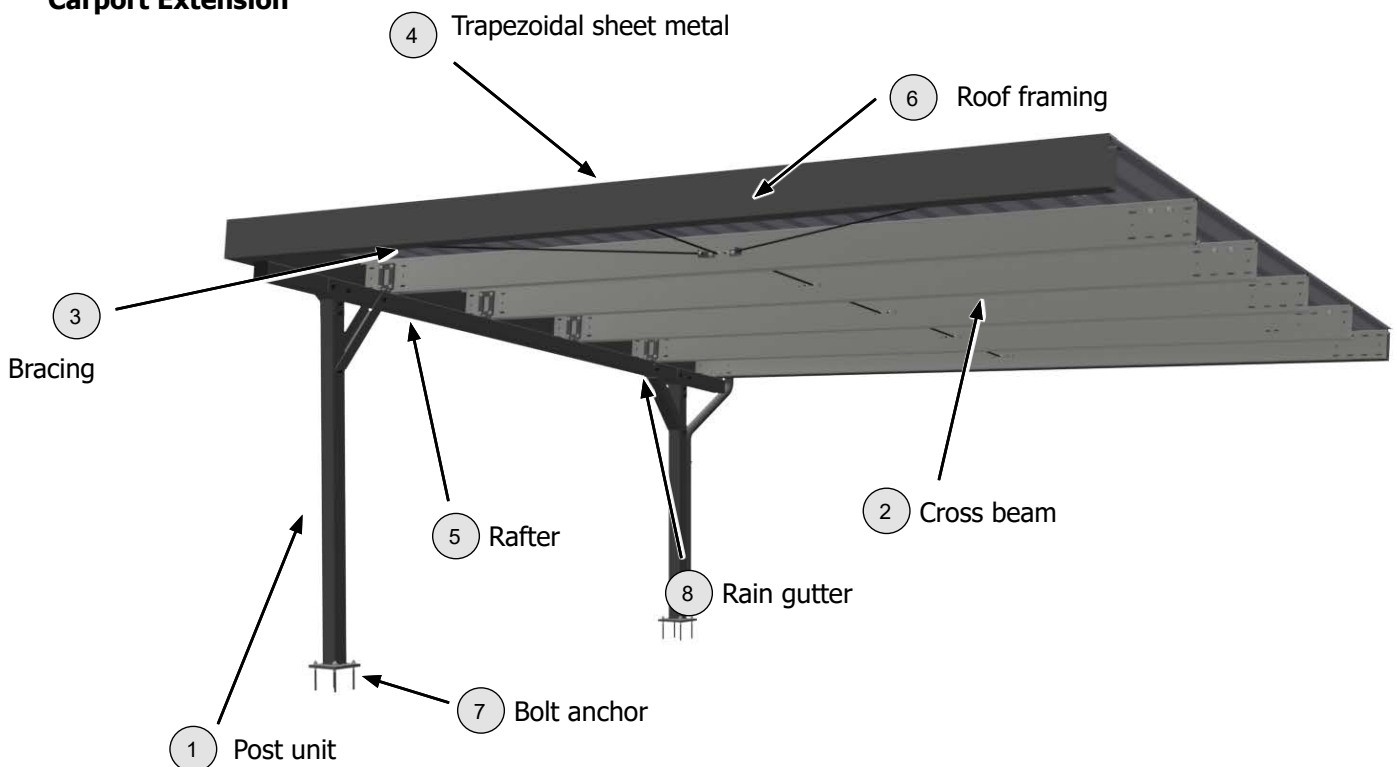

Planning the foot position

Draw the required distances of the fixing points on the corresponding concrete foundations as shown below. Pre-drill the corresponding holes in the concrete foundations.

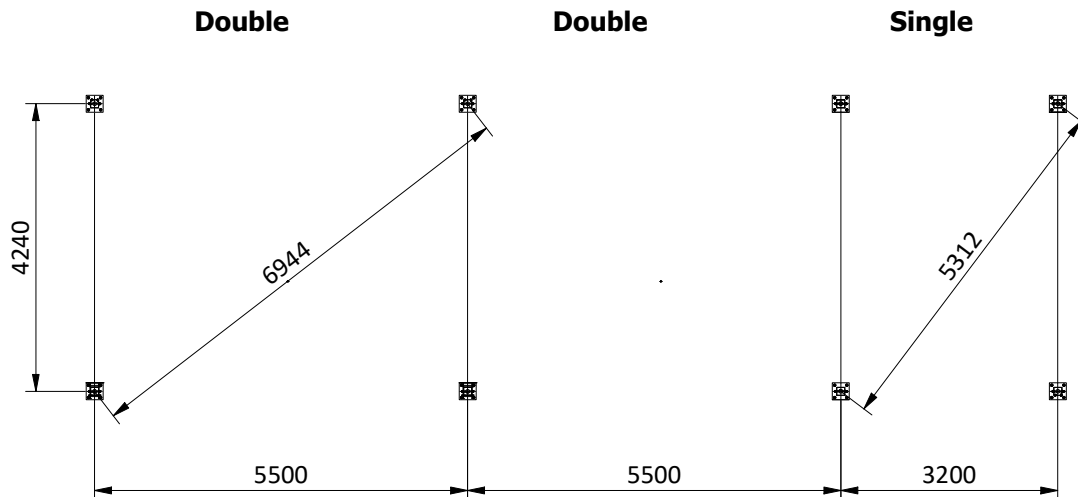

The adjustment plates included in the scope of delivery can be used to compensate for small unevennesses in the foundation.



Blow out the drill holes before setting the bolts later, otherwise the bolts cannot be driven in far enough.

Assembling the post unit

It is recommended to pre-assemble the post unit and then set it up. The individual steps for this are explained below.

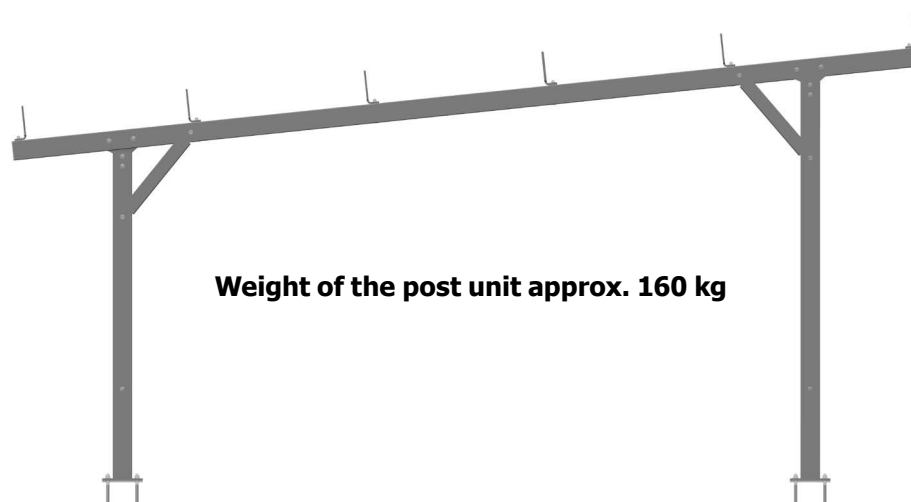

Fastening the brackets to the rafter unit

Attach four middle brackets to the rafter. Two M12x35 cylinder head screws, four washers and two M12 nuts are required per angle. The screws are inserted and fastened from below. Then close the lower holes on the rafter with the cover plugs.

Attach two outer brackets (reversed to the others) to the rafter. Two M12x35 cylinder head screws, four washers and two M12 nuts are needed per angle. The screws are inserted from below.

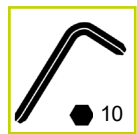

Insert the end caps into the rafter openings on both sides.

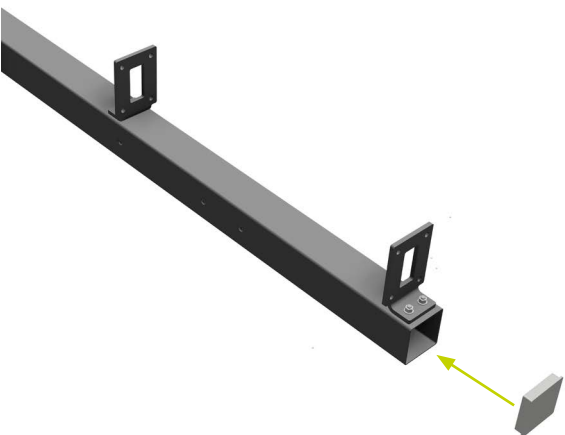
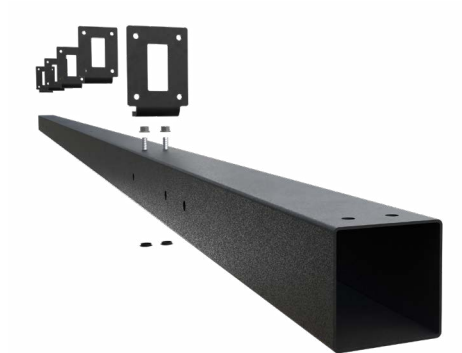

Mounting the optional inverter panel

The optional inverter plate is supplied without holes for the inverter. It is attached to the connection between the support and the rafter instead of a connecting plate. It is fastened with the same four hexagonal screws M16x160 of the connecting plate.

Fixing the rafter to the supports

Fix the front and rear support to the rafter with two connecting plates each, four hexagon bolts M16x160, eight washers and four nuts.

Fasten the gusset plate to the front and rear support with the rafter using two M16x150 hexagon bolts, four washers and two nuts each, similar to the previous step. To set up, tighten the fasteners only hand-tight so that the frames can still be aligned. After aligning and tightening, the respective cover caps of the lanyards can be attached.

Place one post unit at a time on the pre-drilled concrete foundations. Use the shims to compensate for small unevenness in the foundation. Secure the feet to the concrete foundation using 4 bolt anchors each. Do not tighten the bolt anchors until the rest of the steel substructure has been installed, using the tightening torque specified below. The bolt caps can then be attached. Tightening torques: Bolt anchor M20 = 200 Nm.

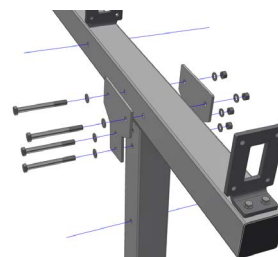
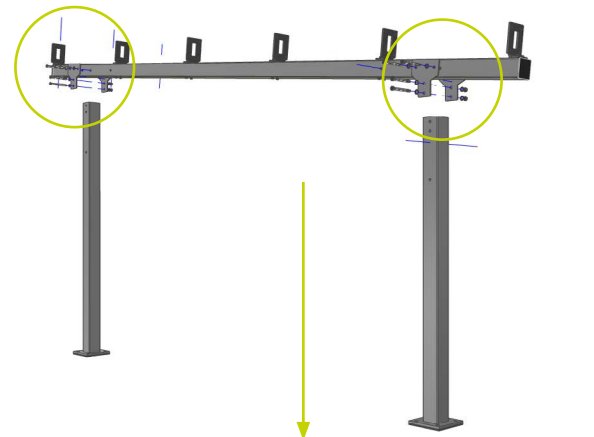

Fastening with connecting plate

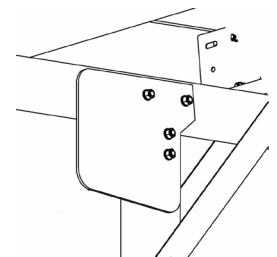

Fastening with optional inverter plate

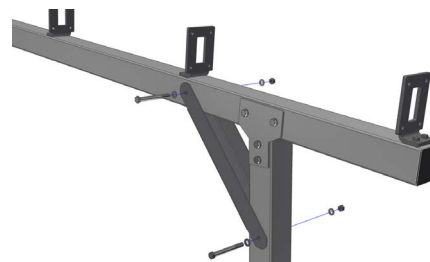

Mount the bolt anchor with 200 Nm.



When driving in the bolts, pay attention to the coating of the posts. We recommend a piece of wood to avoid accidental damage.

Installing the cross beams on the substructure

Carport Single und Double

Place the cross beams on the post units.



If you use the Carport Extension, please continue on page 19 to section 2.3.3.2 Carport Extension.

Mount the cross beams to the angles of the two post units using four M12x35 hexagonal bolts, eight washers and four M12 nuts. Subsequently, the screw caps can be put on.

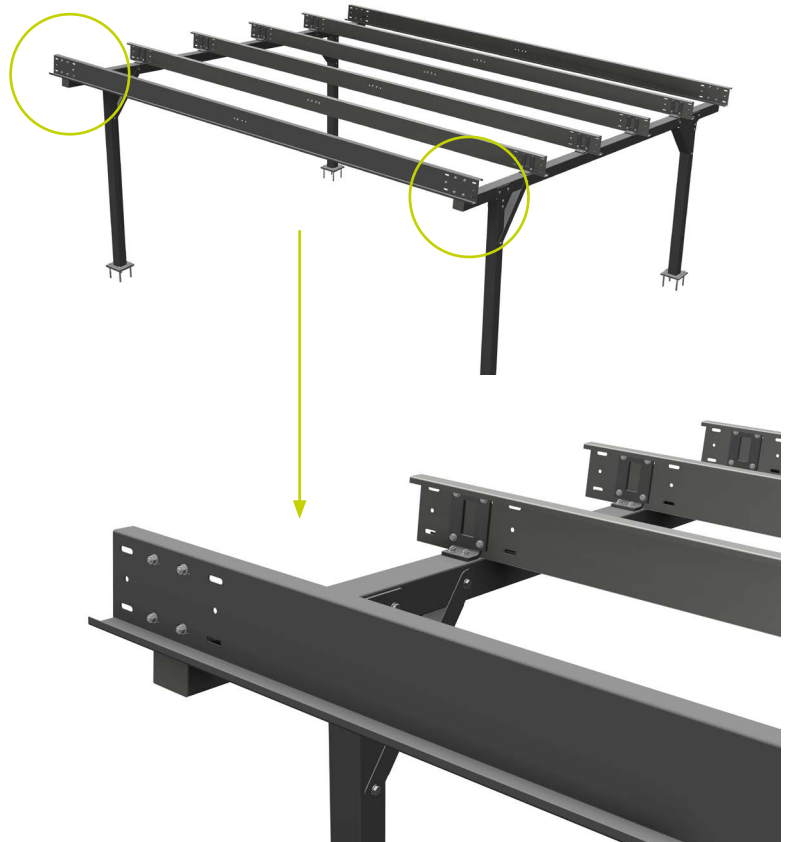

Carport Extension

Mount the cross beams to the angles of the first post unit using four M12x35 hexagon bolts, eight washers and four M12 nuts. Subsequently, the screw caps can be put on.



The cross beams of the Carport Double extension are turned by 180° and pushed into the preceding Z-profile in such a way that the perforations overlap.



Mount the cross beams to the angles of the substructure using four M12x35 hexagon bolts, eight washers and four M12 nuts. In addition, connect the cross members to each other with four M12x30 hexagon bolts, eight washers and four M12 nuts. The screw caps can then be attached.

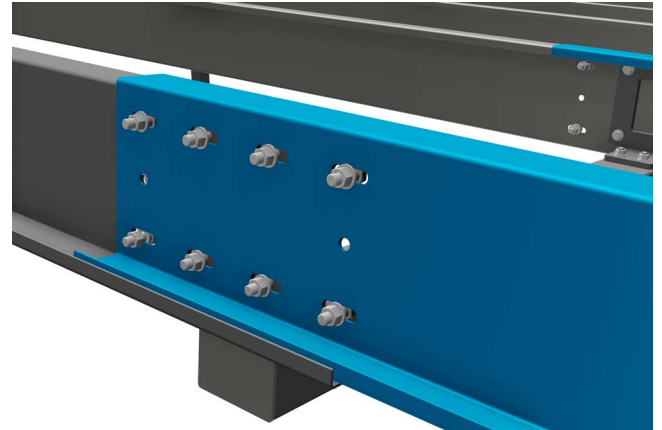

Finally, mount the cross beams to the angles of the last post unit using four M12x35 hexagon bolts, eight washers and four M12 nuts. The screw caps can then be attached.



Completion of the Carport Extension



Fasten bracing to the construction (only for Carport Double and Extension)

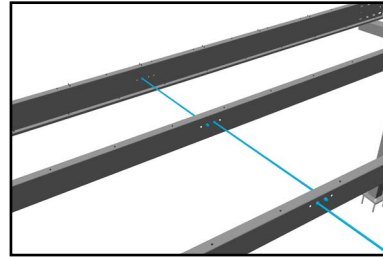
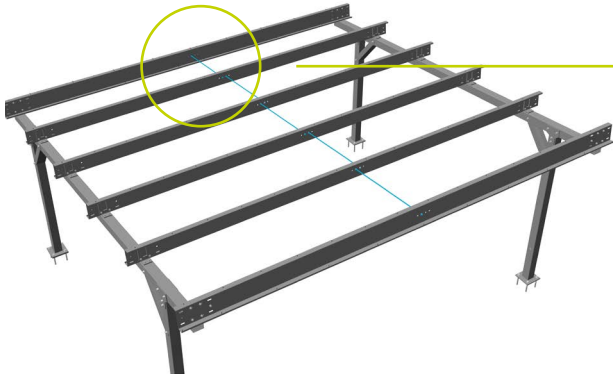

Attach the 5 stiffeners/threaded rods of different lengths (see parts list), staggered one after the other, to the cross member using two washers and two M12 nuts on each side. This means that 4 nuts and 8 washers are needed per threaded rod. Starting from the eaves side, the threaded rods are installed in ascending order of length.

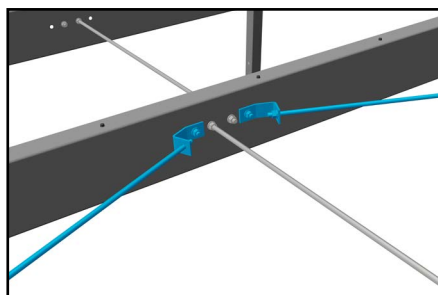
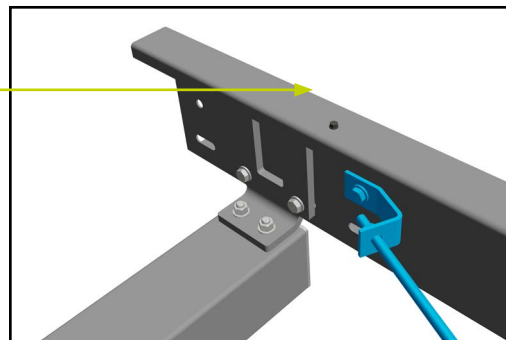
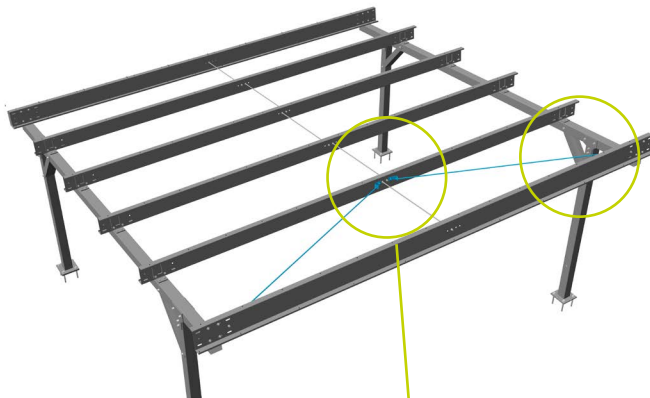

Now fasten the 2 inclined stiffeners/ threaded rods with a length of threaded rods with a length of 2,700mm to the cross member using hexagon bolts M12x30. Two fastening plates are required per threaded rod. Use two washers and two M12 washers and two M12 nuts per fastening plate. In the the corresponding screw caps can be can then be fitted.

Mounting the gutter brackets, the trapezoidal sheet metal and the panels

Mounting the gutter bracket



The gutter brackets and the trapezoidal sheets are installed in one step, as the gutter brackets are fixed under the high beads of the trapezoidal sheets. To do this, the trapezoidal sheets are placed on the purlins and brought into the correct position. Then push the trapezoidal sheets slightly backwards on the eaves side. Distribute the gutter brackets along the length of the roof (distance between the hooks approx. 65 cm). Choose an even distance between the roof hooks. Draw the respective position of the hooks beforehand.

The roof hooks are placed against the cross beams from above and fastened from above in the holes provided in the gutter brackets using two self-drilling screws 5.5x22 without sealing washer per hook. Ensure a slope of 2 % in the direction of the downpipe. We recommend using screw clamps for assembly.

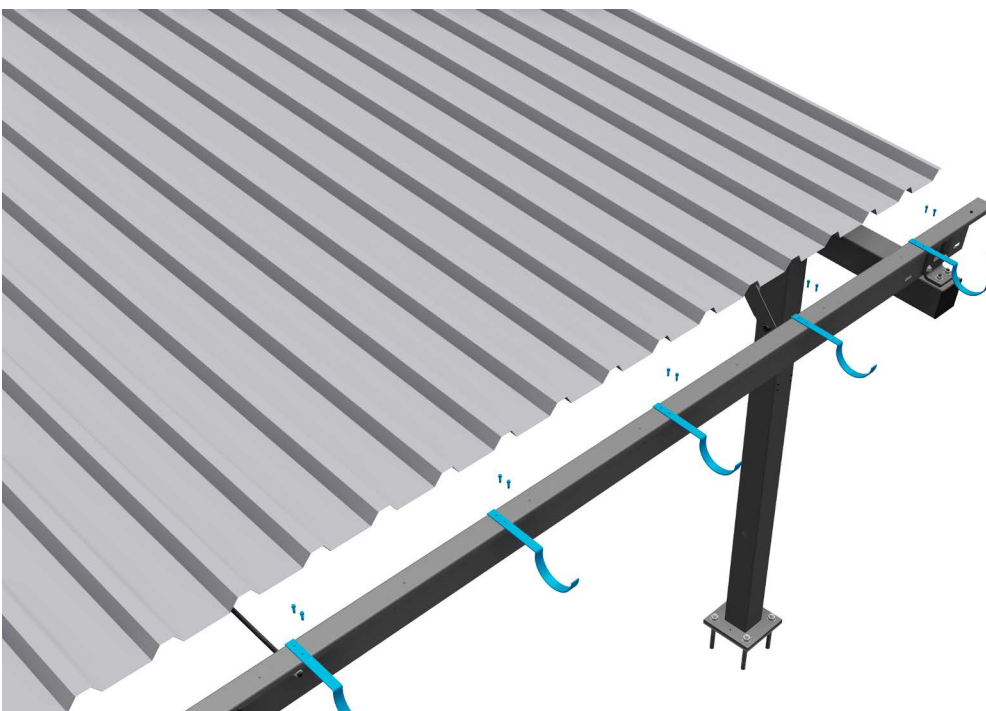

Mounting the trapezoidal sheet

Now push the trapezoidal sheets forward again into the correct position. Then fix the trapezoidal sheets to the cross beams in the deep beads using 5.5x19 mm self-drilling screws with sealing washers. The trapezoidal sheets are screwed in every second deep bead; two screws per metre are necessary for this.

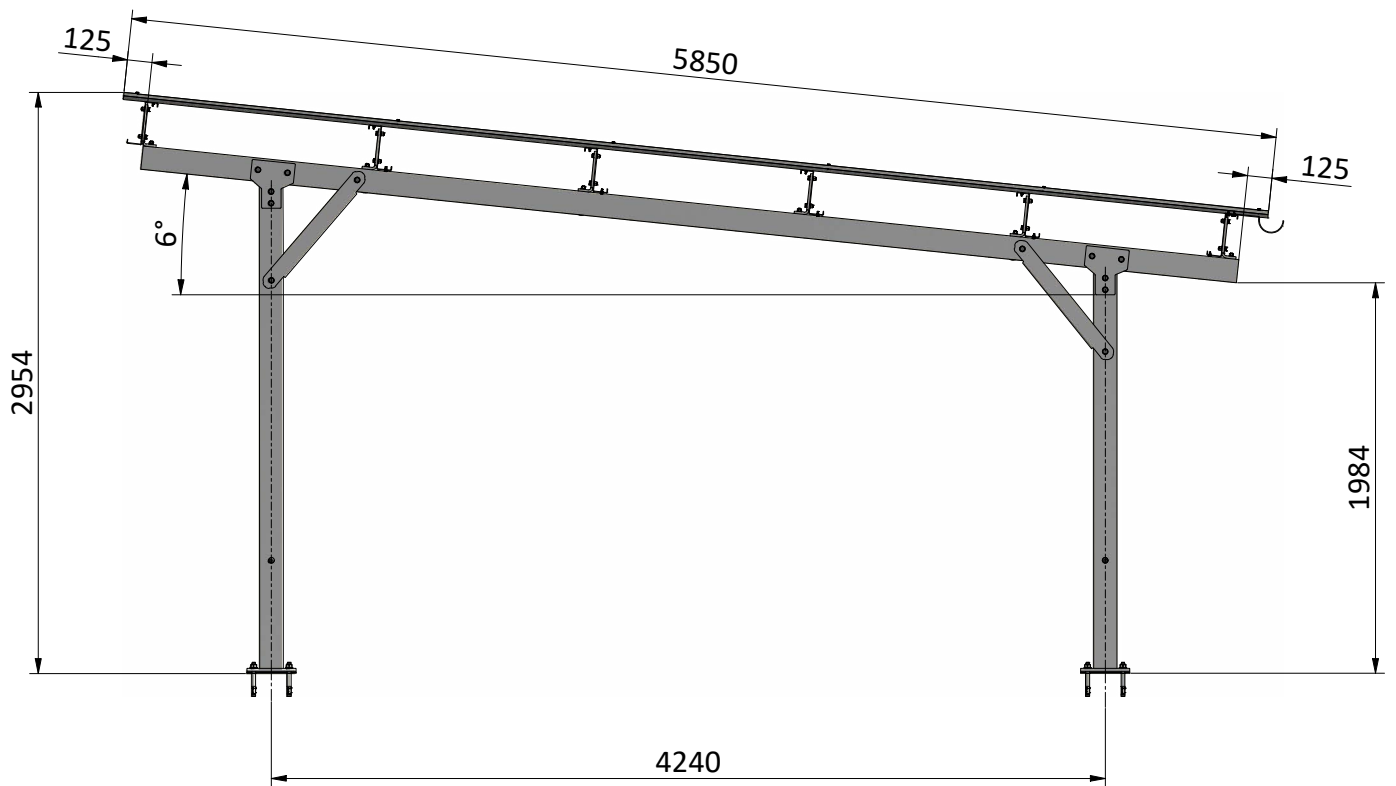
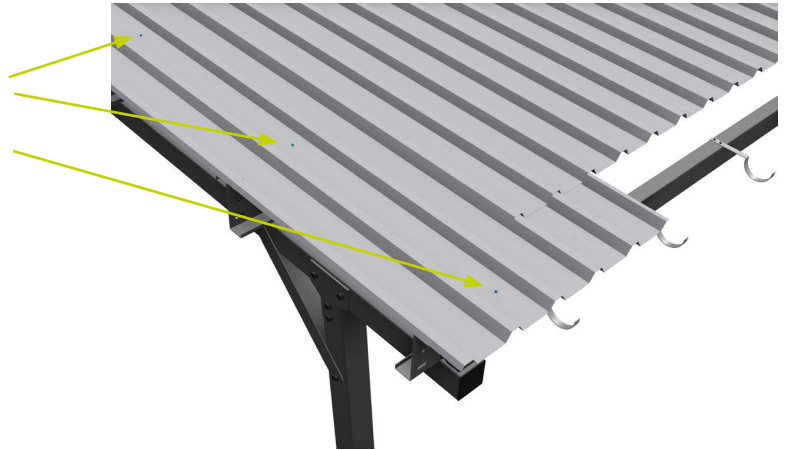

Mounting the panel on the substructure

Start on the eaves side with the smaller panel with a width of 258 mm (shown here in blue) and put the second panel with a width of 260 mm over it. Then repeat this procedure on the other side.

Attach the panels to the cross members from above and below using the 5.5x19 self-tapping screws.

Then the remaining panels are attached to the ridge, overlapping and alternating, using 5.5x19 self-tapping screws on the cross beams from above and below.

Use two self-tapping screws each to fix the overlap at the corner from above and from below.

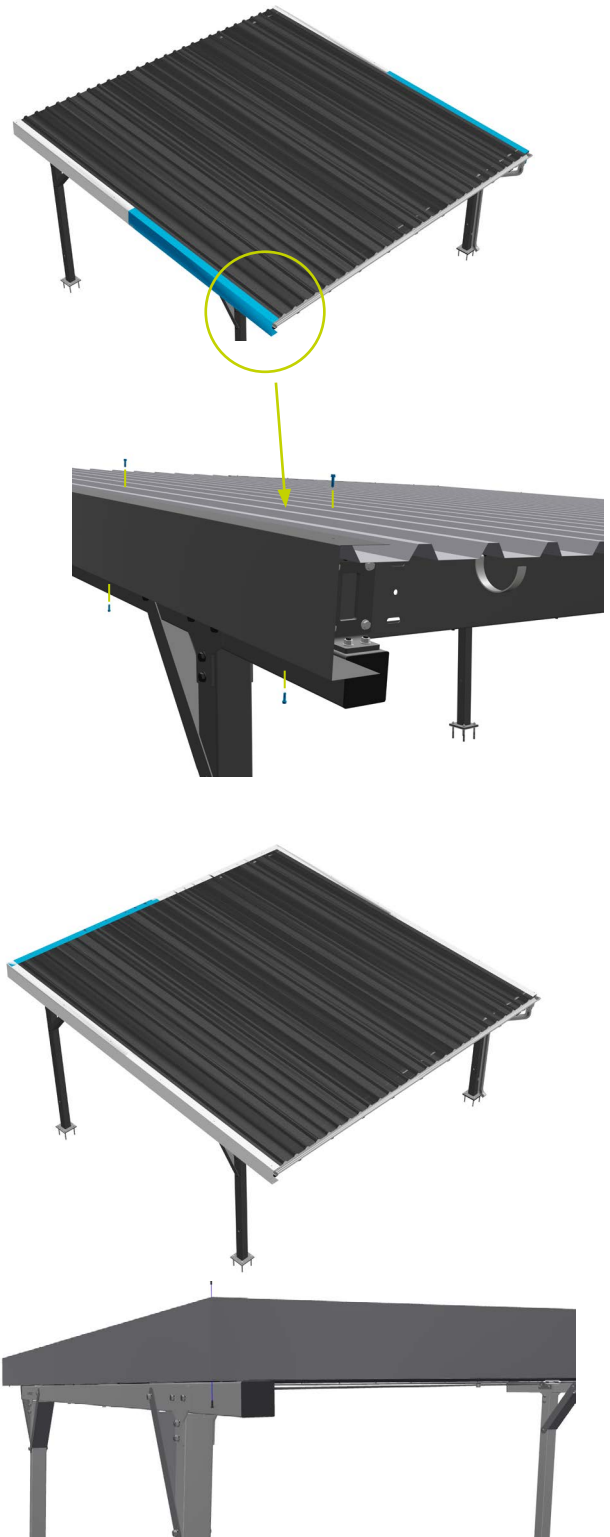

Fasten the panels to the eaves purlin with the 5.5x19 mm self-drilling screws with sealing washer from the front and from below. Above the rafters, cut out the short arm of the L-sheet using tin snips.

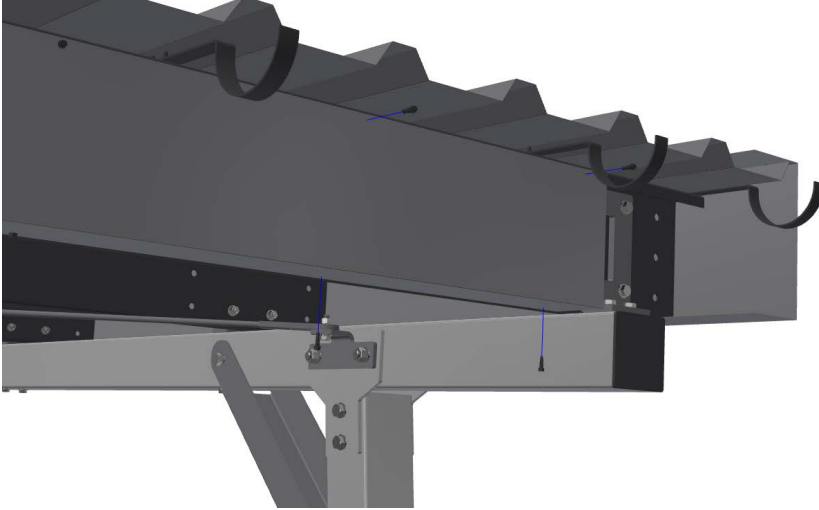

Mounting of the gutter and the associated downpipe

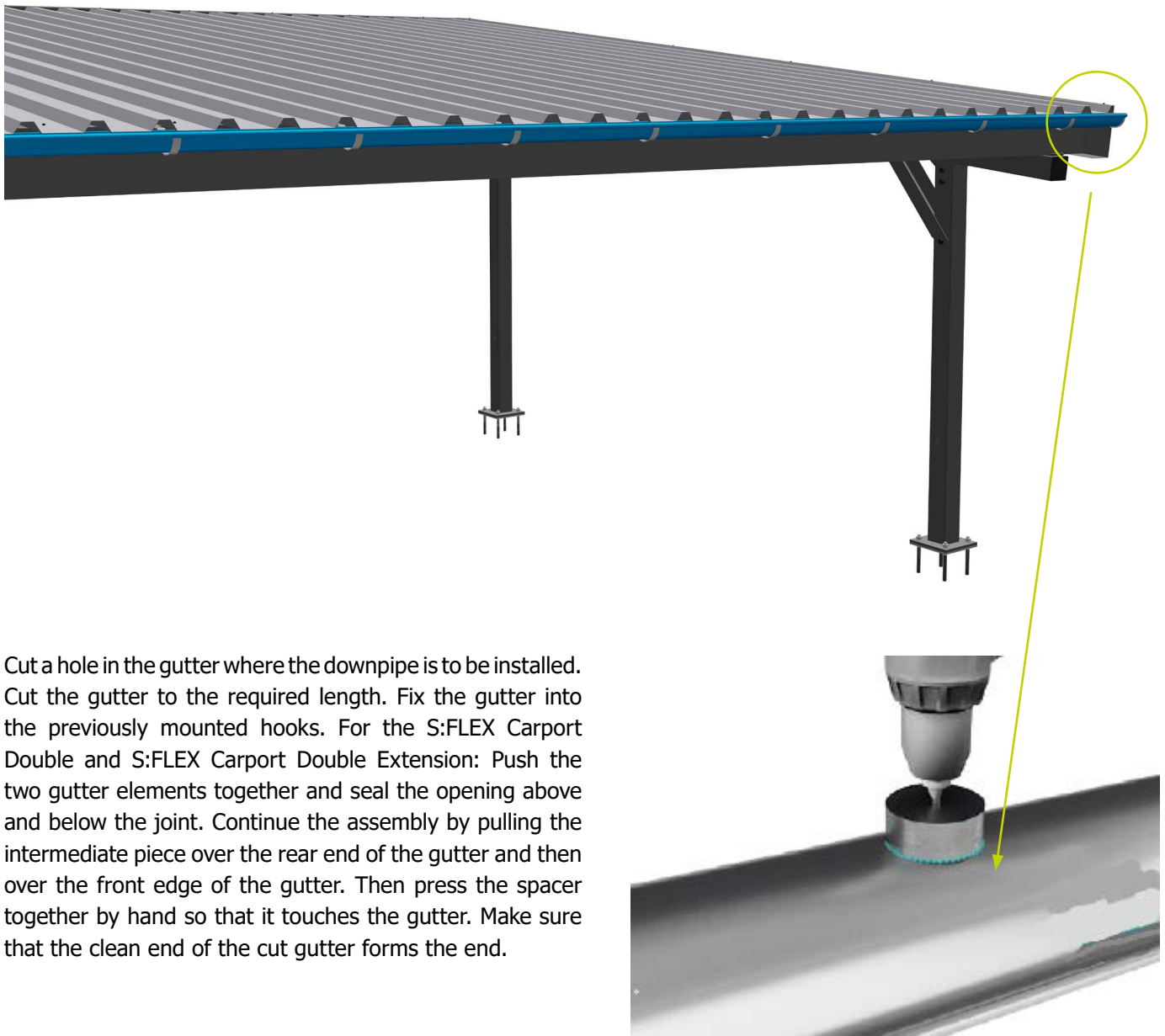

Cut a hole in the gutter where the downpipe is to be installed. Cut the gutter to the required length. Fix the gutter into the previously mounted hooks. For the S:FLEX Carport Double and S:FLEX Carport Double Extension: Push the two gutter elements together and seal the opening above and below the joint. Continue the assembly by pulling the intermediate piece over the rear end of the gutter and then over the front edge of the gutter. Then press the spacer together by hand so that it touches the gutter. Make sure that the clean end of the cut gutter forms the end.

Then bend the latch until the clasp snaps into place. Then proceed as follows:

- Fix the gutter with the gutter socket
- Insert all-pipe bends into the drain
- Attach pipe clamps
- Attach downpipe
- If necessary, saw the downpipe to size and bevel it.

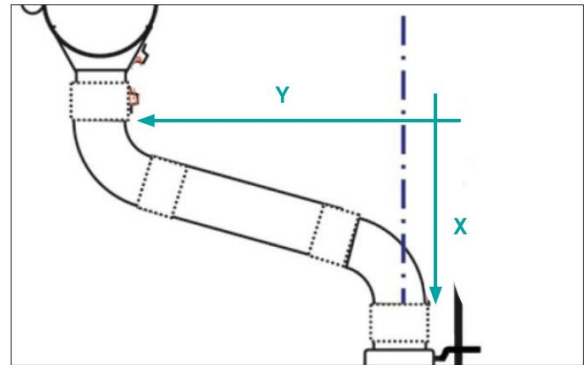

The 3m long downpipe is divided into two elements, downpipe and intermediate piece.

- Attach the funnel for the downpipe to the gutter with the hole already cut out.
- Attach the downpipe to the support (3) with the pipe clamps.
- The length of the intermediate piece is determined by the overhang of the roof.
- Measure the distance X and then use the adjacent table to find out how long the intermediate piece must be.
- The push-in sleeve is used to connect the intermediate piece and the middle elbow.
- The downpipe clamp is placed approx. 10 cm below the upper elbow and 10 cm above the lower elbow.

X [cm]	80	70	60
Length of the spacers [cm]	approx. 70	approx. 60	approx. 50

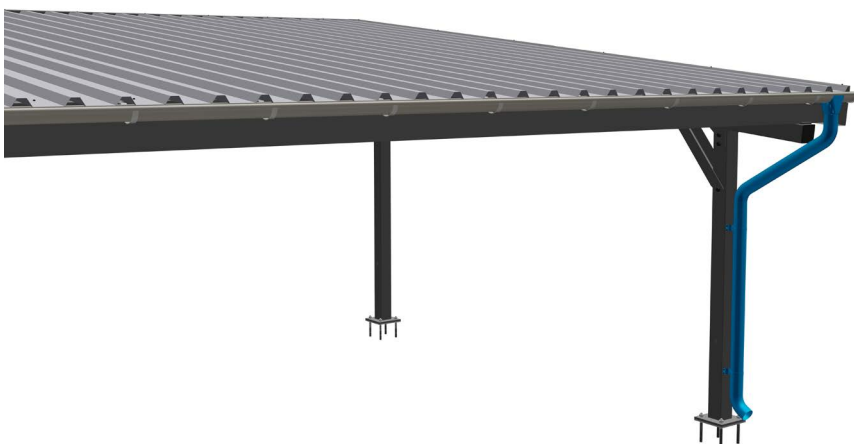

Disassembly

Disassembly of the S:FLEX mounting system may only be carried out by trained specialist personnel. Observe the same safety instructions, standards and guidelines as provided for the installation.

In general, disassembly is carried out in reverse order to the described installation.

Disposal

The S:FLEX mounting system is made from aluminium, stainless steel and steel components. These materials can be recycled after disassembly.

The frame system must only be disposed of by a specialist waste management company. Observe the applicable national standards and guidelines.

User agreement for use of the Carport

We expressly point out that the assembly system is sold under a purchase agreement.

Its installation/processing or acquisition by a third party is not carried out in the name of, or on behalf of, S:FLEX GmbH. Installation/processing of the system must be carried out by appropriately qualified personnel and strictly in accordance with the installation instructions.

The design and planning of the system must be undertaken using the S:FLEX Planning Software. S:FLEX GmbH is neither responsible for the project-specific structural analysis of the roof structure, nor for obtaining and documenting the approval of the roof manufacturer for use of the respective fastening system on the roof in question (in the terms of the warranty), nor for correct installation of the fastening system.

S:FLEX GmbH accepts no liability for faults and damage and/or a restricted or limited operational capability of the system which has resulted from incorrect installation and/or installation which was not undertaken in accordance with the installation instructions and/or the project report. In the case of incorrect installation, the buyer's right to assert claims for material defects shall expire.

The system warranty is only valid if all system components were acquired from S:FLEX GmbH.

Warranty / disclaimer

The information regarding dimensioning provided in these instructions is merely suggested values based on prior experience. Binding structural analyses for installation frames can be created using the S:FLEX planning software.

As an installation company, you are responsible for the correct execution of the installation. S:FLEX GmbH is not liable for the dimensional information contained in commercial system quotations.

As the installation company, you are responsible for the mechanical durability of the installed interface connections on the building envelope, in particular also for their watertightness. The components supplied by the company S:FLEX GmbH are designed for the expected loads and in accordance with the currently available technology.

In this context, you must provide the company S:FLEX GmbH with information about all general technical conditions in writing via the project data collection sheet (information about the supporting structure, snow load zone, building heights, wind loads, etc.).

S:FLEX GmbH is not liable if the installed components are not properly handled. Any use close to the sea needs to be clarified with S:FLEX GmbH directly on a case-by-case basis due to the increased risk of corrosion. Provided that the system is handled properly and dimensioned according to the structural conditions and normal environmental and ambient conditions, the company S:FLEX GmbH provides a warranty from transfer of risk to the warranty holder, which guarantees that the metallic components of the racks will remain free from defects with regard to material and workmanship for a period of 10 years. This warranty does not apply to wear parts. For additional information, please refer to the separate warranty provisions.

This applies within the context of the generally prevalent weather and environmental conditions.