

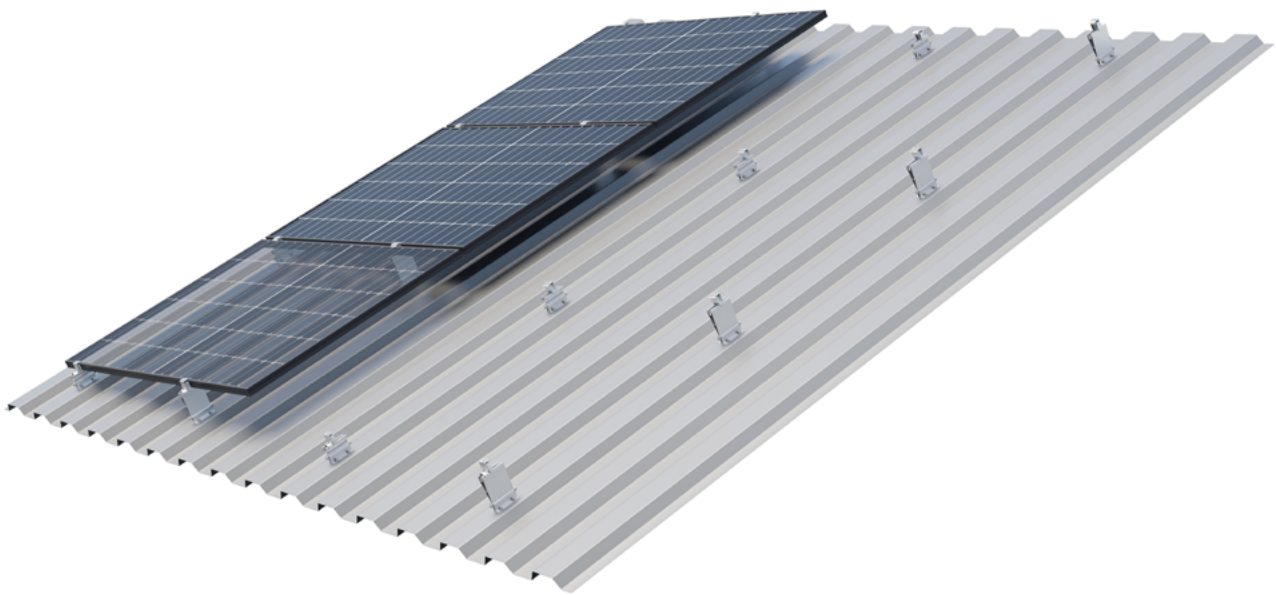

Assembly Instructions

HS RAIL LIFT

High-bead rail for trapezoidal sheet metal roofs



1 Introduction

1.1	Intended Use	3
1.2	About this document	3
1.3	Warnings	4
1.4	General information - standards and guidelines	4
1.5	Description of the system	6

2 Installation - S:FLEX HS RAIL Lift

2.1	System components	7
2.2	Direct roof connection using sheet metal screws	8
2.3	Installation of single-layer substructure	9

3 Disassembly and disposal

3.1	Disassembly	18
3.2	Disposal	18

4 Terms of use and warranty

4.1	HS Rail Lift user agreement	19
4.2	Warranty/ disclaimer	19

These installation instructions must be read carefully before installing the S:FLEX mounting system and kept for future reference!

These installation instructions are only complete with the project-related implementation planning (project report)!

The lightweight, material-efficient design and pre-assembly of the S:FLEX HS RAIL Lift with 4 holes and sealing tape ensure quick installation on trapezoidal sheet metal roofs. Using the appropriate fasteners (sheet metal screws), the rails are attached directly to the raised beads of the trapezoidal sheet metal and fitted with easy-to-insert adapters as module supports.

The S:FLEX HS RAIL Lift offers a simple and effective solution for PV systems on flat and only slightly inclined roof surfaces: Thanks to the different heights of the adapters, an angle of attack of approx. 5° is achieved for upright mounting and approx. 7° for transverse mounting. For an optimised angle of incidence and better self-cleaning of the modules - and therefore significantly higher yields.

All components are made of aluminium and stainless steel. The high corrosion resistance guarantees a maximum service life and offers the possibility of complete recycling.

1.1 Intended Use

The S:FLEX HS RAIL Lift is designed for mounting PV modules. The system is intended for use on trapezoidal sheet metal roofs with an angle of inclination of approx. 5° for upright mounting and approx. 7° for transverse mounting.

Any use that deviates from this must be considered improper. In particular, compliance with the information in these installation instructions is part of the intended use.

An important part of these installation instructions is the supplied, system-specific project report, in which the static calculation was carried out on a site-specific basis. The S:FLEX HS RAIL Lift must be designed and planned using the S:FLEX planning tool.

S:FLEX GmbH is not liable for damage resulting from non-compliance with the installation instructions or from misuse or improper use of the product.

1.2 About this document

These installation instructions describe the installation of the S:FLEX HS RAIL Lift on flat pitched trapezoidal sheet metal roofs.

These installation instructions describe the installation with HS RAIL incl. lift insert. This is possible with trapezoidal sheet metal roofing.

It must be ensured that only current and complete installation instructions are used for installation.

1.3 Warnings

The warning notices used in these installation instructions indicate safety-relevant information. They consist of:



Unless observed, there is a major risk of injury as well as a risk of death.



Failure to observe this may lead to property damage.

1.4 General information – standards and guidelines

Every photovoltaic system must be installed in accordance with the instructions contained in the respective installation guidelines and the project report.

These installation instructions are based on state-of-the-art technology and many years of experience of installing our systems on site. It must be ensured that only the current and complete installation instructions are used for the installation, and that a print-out of the installation guidelines is stored in the immediate vicinity of the system. The system and these guidelines are subject to technical changes.

The project report is part of the installation instructions and is created on a project-specific basis. All of the information contained in the project report must be strictly observed. The project report contains the location-based static calculations. The S:FLEX mounting system must be designed and created with the S:FLEX software.

Since individual project-specific features must be considered with every roof, expert advice must always be sought prior to installation. Before installation, the PV system creator must ensure that the existing roofing and roof substructure are suitable for the additional loads. The condition of the roof substructure, the quality of the roof covering and the maximum load-bearing capacity of the roof construction must be checked by the system creator. Contact a local structural engineer for this purpose.

When installing the PV system, always comply with the module manufacturer's installation instructions. In particular, it is necessary to check that the module manufacturer's instructions regarding the module clamping guidelines (module clamping surface and clamping range) are complied with. If this is not the case, the customer must obtain a declaration of consent from the module manufacturer before the installation; alternatively, the mounting system must be adapted in accordance with the module manufacturer's specifications.

The requirements for the protection of PV mounting systems against lightning and surges must be met in accordance with the DIN and VDE regulations. The specifications of the relevant power supply company must be observed.

Care must be taken that the PV system to be installed does not impair the functioning of the existing lightning protection system. It is also important to ensure that the PV system is designed so that it can be included in the protection zone of the building's lightning protection system. The separation distances between the PV system and the lightning protection system specified in the relevant regulations must be adhered to. During installation, the local fire regulations must be observed, e.g. firewalls must not be built over and the required clearances must be maintained.

If the roofing is altered, the manufacturer's guidelines must be observed. During and after installation, the frame components may not be stepped on or be used as a climbing aid. There is a risk of falling and the roofing underneath could be damaged.

Prior to installation, the creator of the photovoltaic system must ensure that the installation is carried out while strictly adhering to national and location-specific building regulations, safety and accident prevention regulations, standards and environmental protection regulations.

Every person who installs the S:FLEX PV mounting systems is obligated to independently inform himself/herself about all rules and regulations for professionally correct planning and installation, and to comply with said rules and regulations during the installation process. This also includes compliance with the latest versions of the respective rules and regulations.

Installation of the PV system may only be carried out by trained specialists.



All system components must be checked for damage before installation. Damaged components must not be used!



Installation of the S:FLEX substructure and the PV system may only be carried out by trained specialists. System components must not be used as step ladders. The modules must not be stepped on. When working on roofs, there is a risk of falling off and falling through roofs. A fall can result in injury or death. Ensure that appropriate climbing aids and fall-protection equipment (e.g. scaffolding) are provided as well as protection from falling parts.



Check the building statics and construction/condition of the roof substructure before starting the installation. During installation, the instructions in the installation guidelines and project report must be strictly observed. Failure to observe the installation guidelines and the project report may result in damage to the PV system and to the building.

1.5 Description of the system - HS RAIL Lift

The S:FLEX HS RAIL Lift offers suitable solutions for different requirements:

System properties

Application:	Trapezoidal sheet metal and sandwich cladding
Module type:	Framed modules
Variants:	South and east-west mounting
Module orientation:	portrait / landscape
Lift angle:*	approx. 5° for portrait mounting/ approx. 7° for landscape mounting
Roof pitch:	max. 75°
Module field length:	max. 12.00 m
Max. Snow load:	2.4 kN/m ²
Connection:	sheet metal screws on raised beads
Material:	Aluminium EN AW-6063 / T66, stainless steel, EPDM seals
Colour:	Natural, mill finished

Roof covering requirements

Sheet thickness min:	sheet steel 0.5 mm; sheet aluminium 0.5 mm **
Tensile strength R _m min:	sheet steel 235 N/mm ² ; sheet aluminium 165 N/mm ² **
High bead:	35 mm width, of which 30 mm straight contact surface / installation at the high point of the bead

* depending on the clamping range and the distance between the rails

** Calculation basis S:FLEX. National or regional standards may stipulate different values (DIN EN 1090-04 2020-06) and must be observed accordingly.



The module manufacturer's installation instructions must always be observed.

2.1 System components

① Components for roof connections

S:FLEX Lift Adapter Multi front

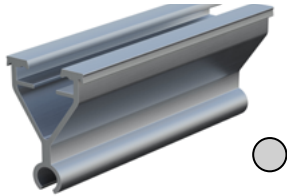

S:FLEX Lift Adapter Multi back

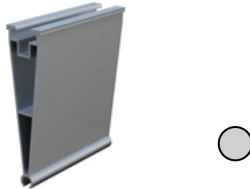

S:FLEX Lift HS rail 100

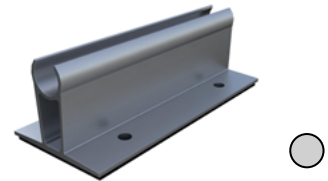

② End clamp

EC AK II Klick
30-50 A

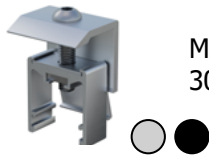

③ Mid clamps

MC AK II Klick
30-50 A

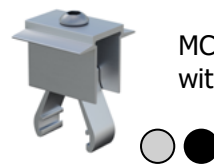

MC AK II Klick 30-50
with grounding plate

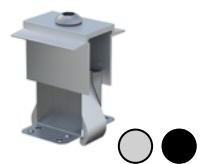

④ Slipping protection

Slider lock AK A

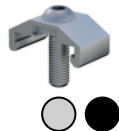

⑤ Sheet metal screw

Sheet metal screw 4,5x25
Sheet metal screw 4,8x20



⑥ Hexagon socket screw

Hexagon socket screw
M8x120 DIN 912 A2



⑦ Serrated nut

Serrated nut
M8 A2 DIN 6923



⑧ Serrated washer

Serrated washer
A4 M8



2.2 Direct roof connection using sheet metal screws

When installing the sheet metal screws, the provisions specified in the building authority approvals for the sheet metal screws must be observed (e.g. area of application, pre-drilling diameter, minimum thicknesses of the materials to be joined, hole diameter for existing perforations).

The corresponding sheet metal screws are part of our delivery. The choice of fasteners depends on the roof covering and the forces that occur. Sheet metal screws should only be used in the area of the raised bead.

Sheet metal screw:

4,5 x 25 A2 / Bimetal

4,8 x 20 A2 / Bimetal



Installation:

- SW 8
- Tool outer dimension (socket spanner) $\leq 15\text{mm}$

2.3 Installation of single-layer substructure

2.3.1 Module alignment south

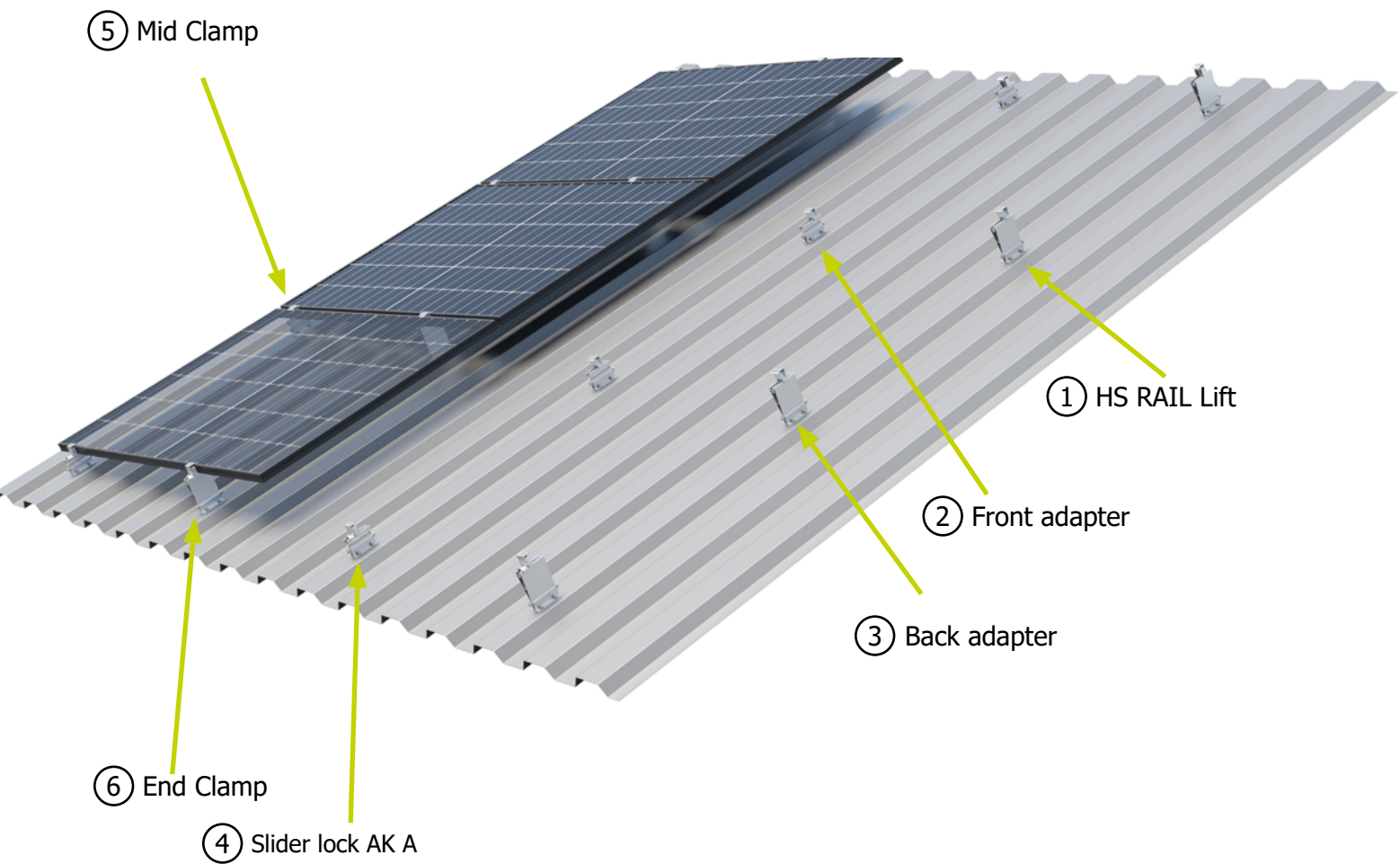

Note: On the following pages, module installation is shown vertical. The module is mounted horizontally according to the same scheme. This requires the module clamps on the short sides to be released.

Installation – 1 (Positioning of the HS RAIL Lift)

The positioning of the Lift HS rail 100 must be determined according to the static requirements of the location and the installation situation. The Lift HS rail 100 must be positioned in such a way that the front and back adapters can later be mounted between the fastening points on the trapezoidal sheet metal. It must be checked again whether the dimensions used in the planning correspond to the dimensions found on the roof (adjustments may have to be made). The fit of the HS RAIL Lift must be checked with the prescribed clamping distances of the modules.

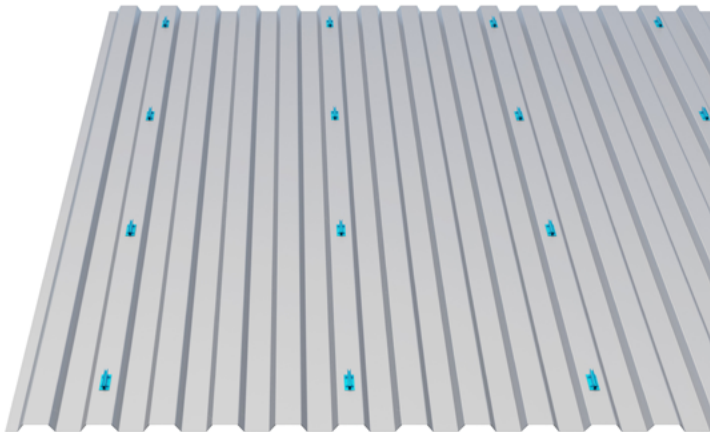

Check planning basis



Positioning according to the static requirements and installation situation



Alignment of the Lift HS rail 100 Lift with alignment line

2 Montage - S:FLEX HS RAIL Lift

Installation of single-layer substructure

Install the Lift HS rail 100 using the appropriate fasteners.

Use 4 sheet metal screws per Lift HS rail 100 (4 sheet metal screws per high bead). To ensure the tightness of the roof covering, the Lift HS rail 100 must always be installed on the high bead. The Lift HS rail 100 is suitable for the standard raised beads/chord widths for min. 35 mm or min. 30 mm straight support surface. Lift HS rail 100 is pre-drilled and covered with EPDM sealing strips on the underside.

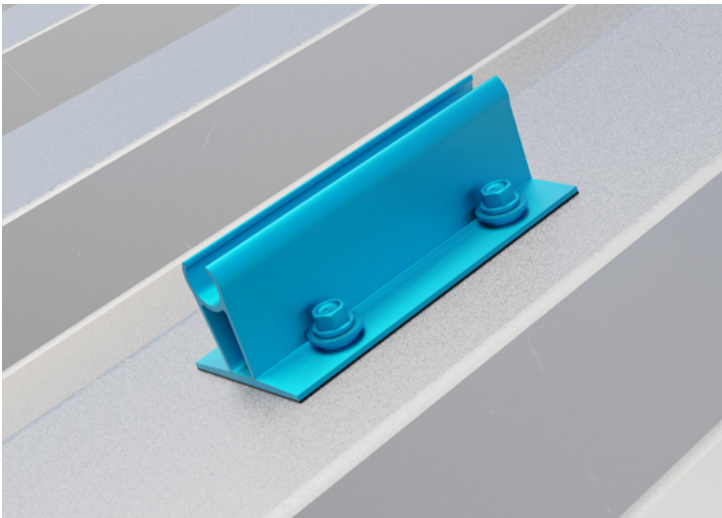

**4 sheet metal screws per
Lift HS rail 100**

2 Installation - S:FLEX HS RAIL Lift

Installation of single-layer substructure

Thread the front and back adapters into the Lift HS rail 100. Fasten each adapter with a hexagon socket screw M8x120, serrated nut M8 and two serrated washers A4 to prevent the adapters from slipping out.

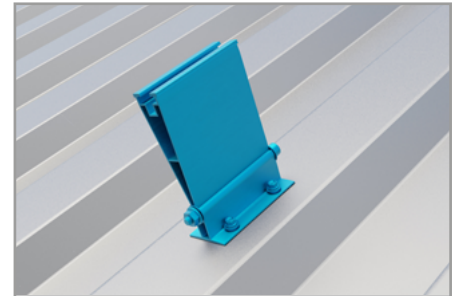
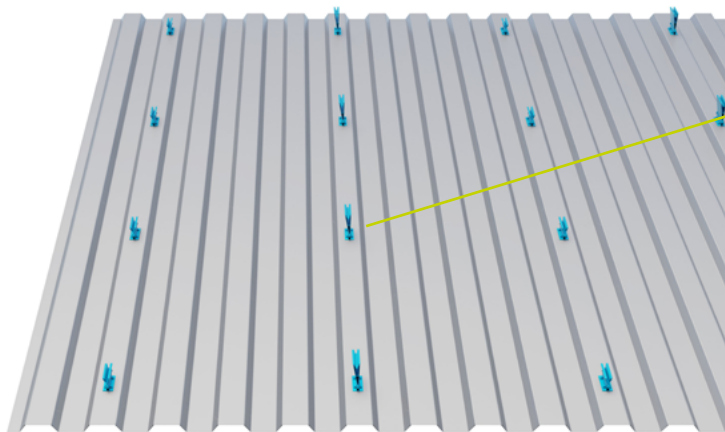

Thread in the adapter and secure with 1x hexagon socket screw M8x120, 1x serrated nut M8 and 2x serrated washer A4 for each adapter and Lift HS rail 100.

Lift HS rail 100 assembly with lift adapter

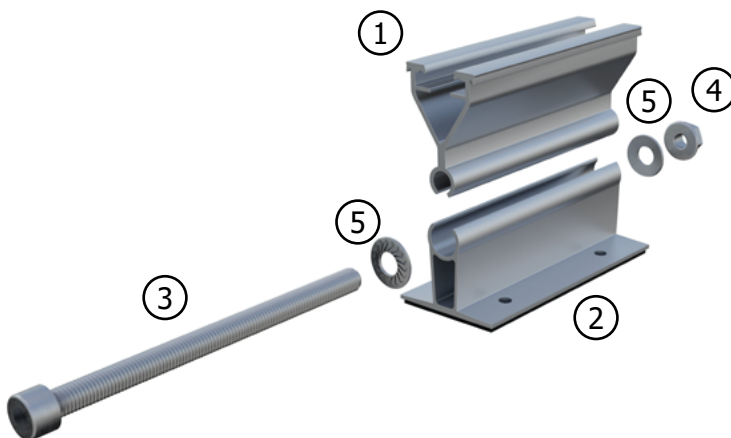

1. Lift Adapter front or Lift Adapter back
2. Lift HS rail 100
3. Hexagon socket screw M8x120
4. Locking nut M8
5. Serrated washer A4

Installation – 2 (Installation of the module, anti-slip protection)

Installation of the module (End clamp at the start of the row)

Place the module on the adapters. Install the end clamps. To do this, click the end clamp onto the adapter and push it flush against the module. Ensure that the end clamp is clicked into place on both sides of the adapter. Now adjust the end clamp to the module height and tighten the screw (tightening torque 8-10 Nm).

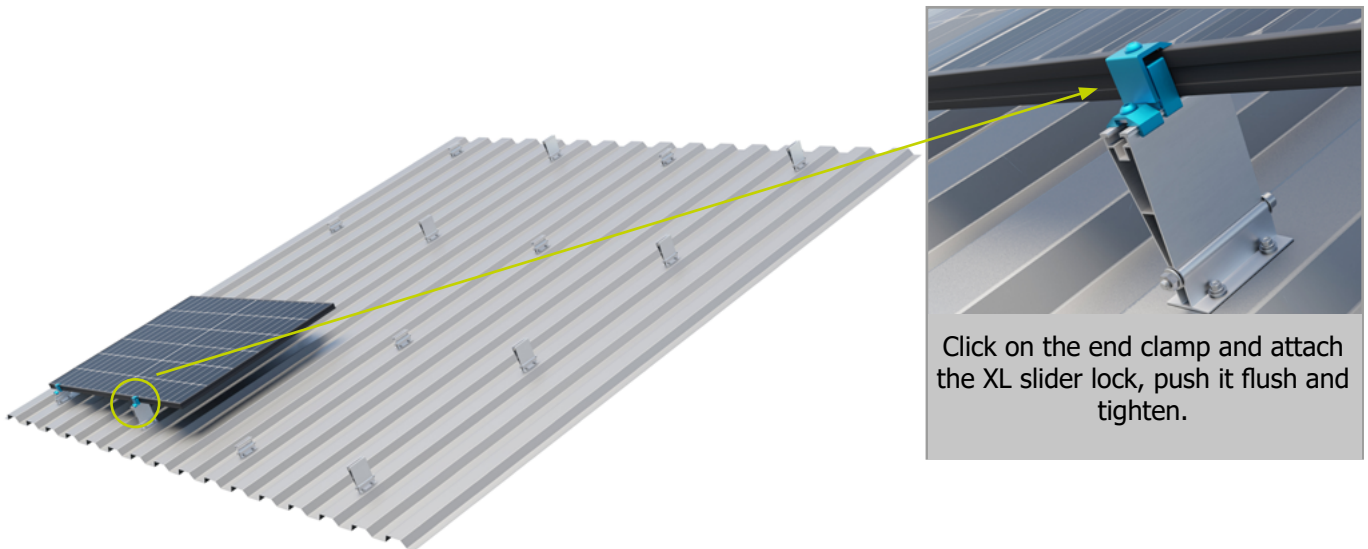

Install end clamps



Ensure that the end clamp clamps the module frame with the clamping surface defined by the module manufacturer. Install the slider lock XL on the back adapters at the end of the module field.

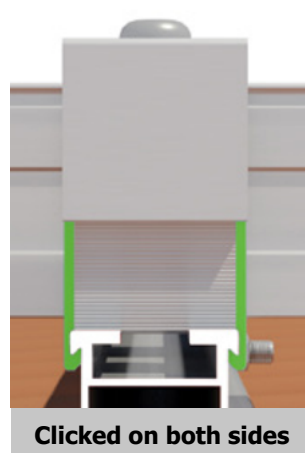

End clamps are approved for one-time installation. Check that the end clamp is clicked into place



Observe the module manufacturer's specifications: Check the defined clamping surface

Module installation (Mid clamp)

Now install the mid clamp. To do this, click the mid clamp onto the adapter and push it flush against the module. Make sure that the mid clamp is clicked into place on both sides of the adapter.

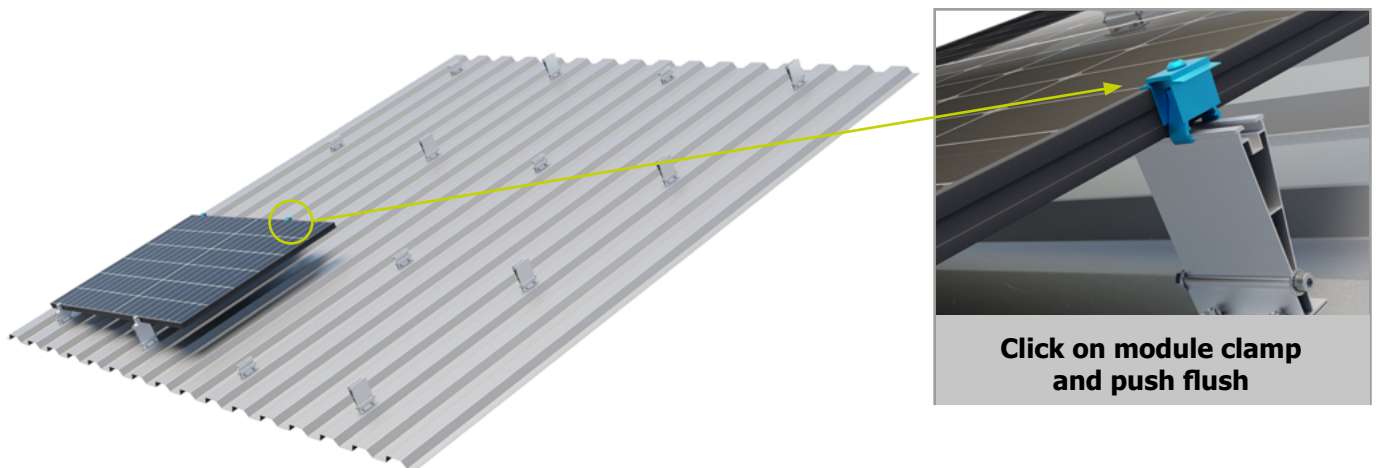

Now slide the next module under the mid clamp, adjust the mid clamp to the module frame height and tighten the screw (tightening torque 8-10 Nm).

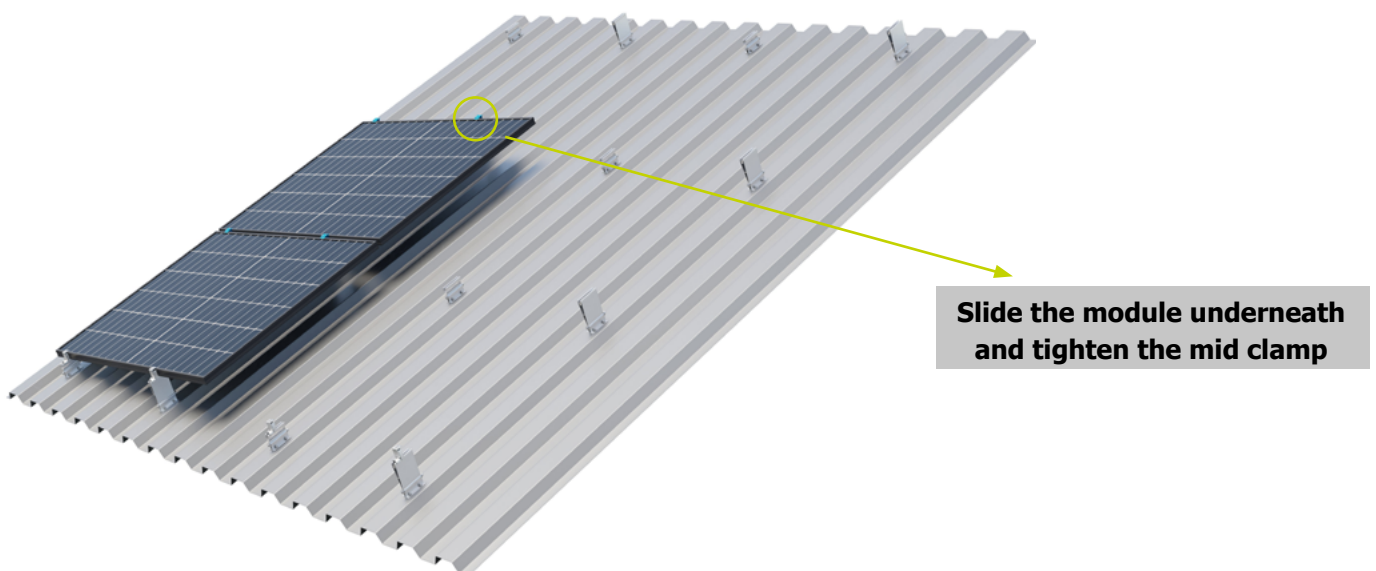

2 Installation - S:FLEX HS RAIL Lift

Installation of single-layer substructure

Ensure that the mid clamp holds the two module frames with the clamping surface defined by the module manufacturer.

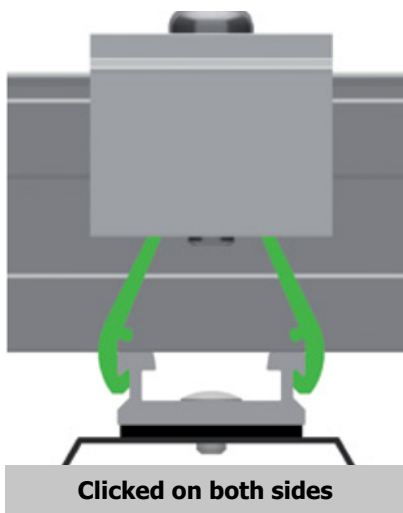
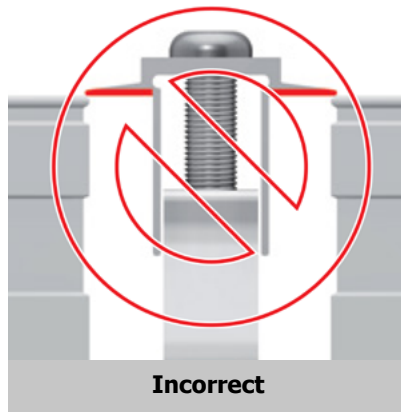
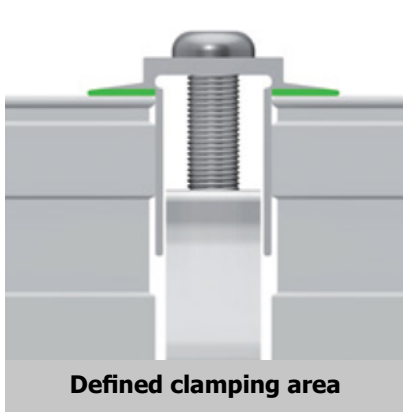

Mid clamps are approved for one-time installation. Check that the mid clamp is clicked into place.



Observe the module manufacturer's specifications: Check the defined clamping area

Module installation (end clamps at the end of the row)

End clamps must be installed again on the last module in the row (if necessary for expansion joints). To do this, click the end clamp onto the adapter and push it flush against the module. Ensure that the end clamp is clicked into place on both sides of the adapter. Now adjust the end clamp to the module height and tighten the screw (tightening torque 8-10 Nm). Make sure that the end clamp clamps the module frame with the clamping surface defined by the module manufacturer.

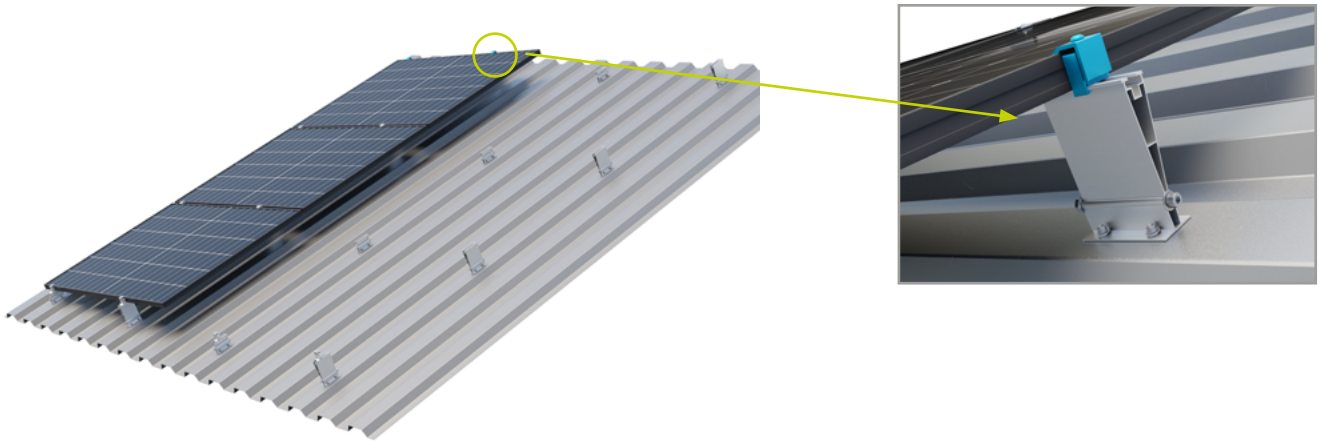

Proceed with the following rows as described.

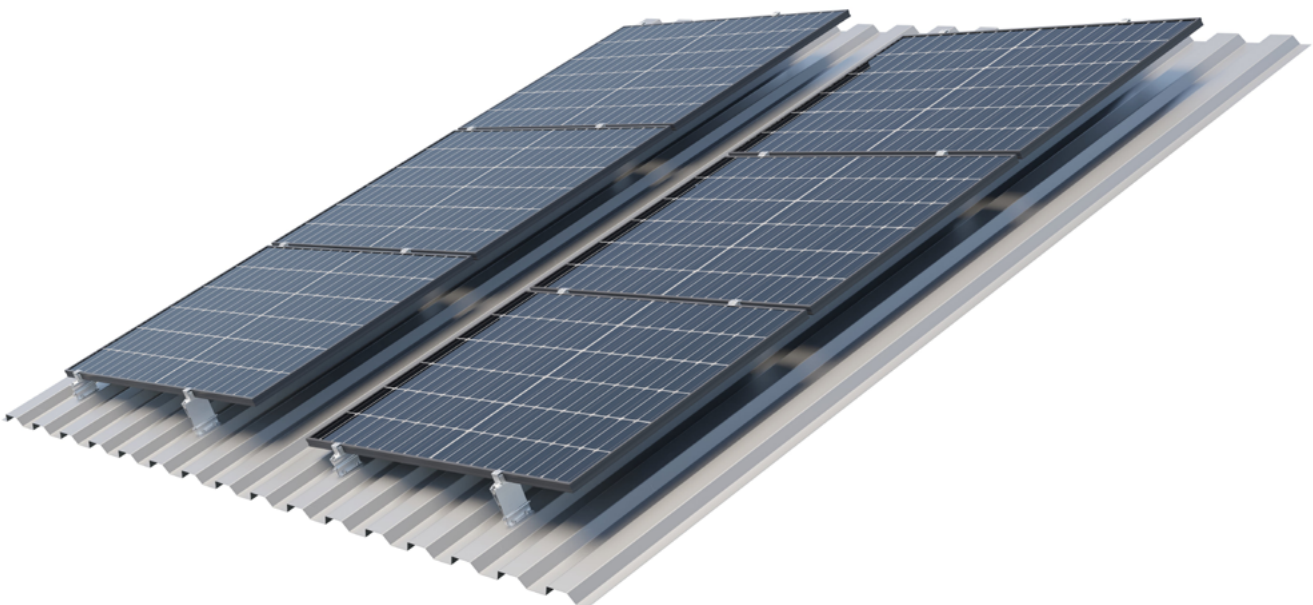

2.3.2 Module orientation E/W

Module alignment of the HS RAIL Lift System can also be installed in E/W alignment. To do this, carry out the installation steps as described in chapter „2.3. Installation of single-layer substructure“ and reposition the Lift Adapter Back and Lift Adapter Front accordingly to align the modules in E/W orientation.

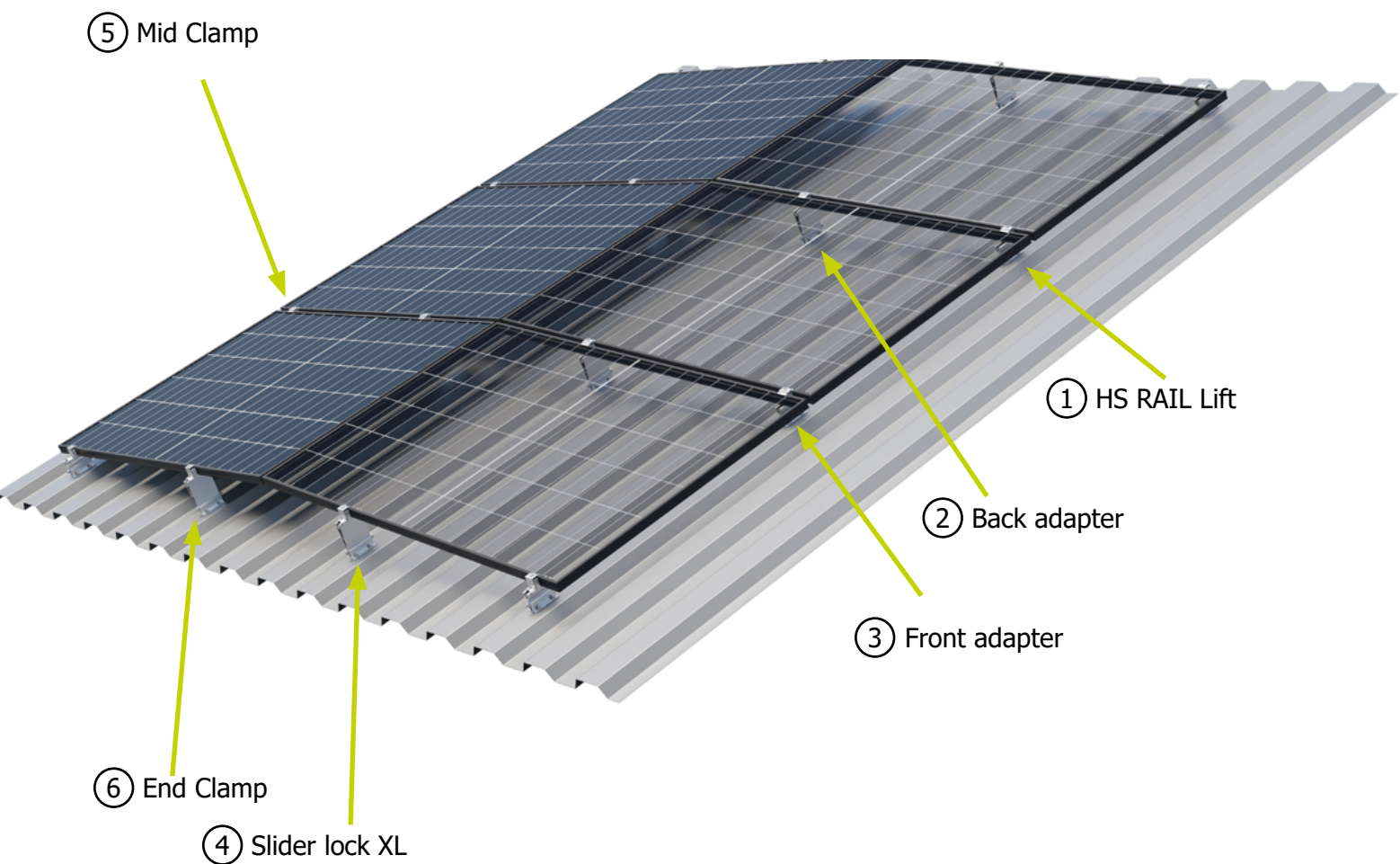

3.1 Disassembly

The S:FLEX mounting system may only be dismantled by appropriately trained specialists. The same safety instructions, standards and guidelines must be observed as for installation. Disassembly is always carried out in the reverse order to that described for assembly.



Before disassembly, disconnect the PV modules from the mains network. Disconnect all of the PV modules' electrical cables (string lines and plug connectors) and remove them from the frame system.



Then remove the modules and store them safely. Improper disassembly can lead to damage to the modules.



Disassemble frame system and safely store all of the parts. Any holes in the roof must be sealed by a specialist.

3.2 Disposal

The S:FLEX mounting system is made from aluminium, stainless steel and steel components. These materials can be recycled after disassembly. The frame system must only be disposed of by a specialist waste management company. Observe the applicable national standards and guidelines.

4.1 User agreement for the HS RAIL Lift

We point out that the assembly system is sold as part of a purchase agreement.

Its installation/processing or acquisition by a third party is not carried out in the name of, or on behalf of, S:FLEX GmbH. Installation/processing of the system must be carried out by appropriately qualified personnel and strictly in accordance with the installation instructions.

The design and planning of the system must be undertaken using the S:FLEX Planning Software. S:FLEX GmbH is neither responsible for the project-specific structural analysis of the roof structure, nor for obtaining and documenting the approval of the roof manufacturer for use of the respective fastening system on the roof in question (in the terms of the warranty), nor for correct installation of the fastening system.

S:FLEX GmbH accepts no liability for faults and damage and/or a restricted or limited operational capability of the system which has resulted from incorrect installation and/or installation which was not undertaken in accordance with the installation instructions and/or the project report. In the case of incorrect installation, the buyer's right to assert claims for material defects shall expire.

The system warranty is only valid if all system components were acquired from S:FLEX GmbH.

The system requires approval for the modules to also be mounted in the indicated manner (i.e. fitted to the modules' shorter sides). This approval can either be given generally as part of the module certification or, as the case may be, issued by the module manufacturer on a project-specific basis.

4.2 Warranty / disclaimer

The information regarding dimensioning provided in these instructions is merely suggested values based on prior experience. Binding structural analyses for installation frames can be created using the S:FLEX planning software.

As an installation company, you are responsible for the correct execution of the installation. S:FLEX GmbH is not liable for the dimensional information contained in commercial system quotations.

As an installation company, you are responsible for the mechanical durability of the interface connections mounted on the building's structure. In particular, this includes ensuring that these are leak-tight. The components supplied by the company S:FLEX GmbH are designed for the expected loads and in accordance with the currently available technology. In this context, you must provide the company S:FLEX GmbH with information about all general technical conditions in writing via the project data collection sheet (information about the supporting structure, snow load zone, building heights, wind loads, etc.).

S:FLEX GmbH is not liable if the installed components are not properly handled. Any use close to the sea needs to be clarified with S:FLEX GmbH directly on a case-by-case basis due to the increased risk of corrosion. Provided that the system is handled properly and dimensioned according to the structural conditions and normal environmental and ambient conditions, the company S:FLEX GmbH provides a warranty from transfer of risk to the warranty holder, which guarantees that the metallic components of the racks will remain free from defects with regard to material and workmanship for a period of 10 years. This warranty does not apply to wear parts. For additional information, please refer to the separate warranty provisions.

This applies within the context of the generally prevalent weather and environmental conditions.